

Amplified Ear

Useful to listen in faint sounds
1.5V Battery operation

Circuit diagram:

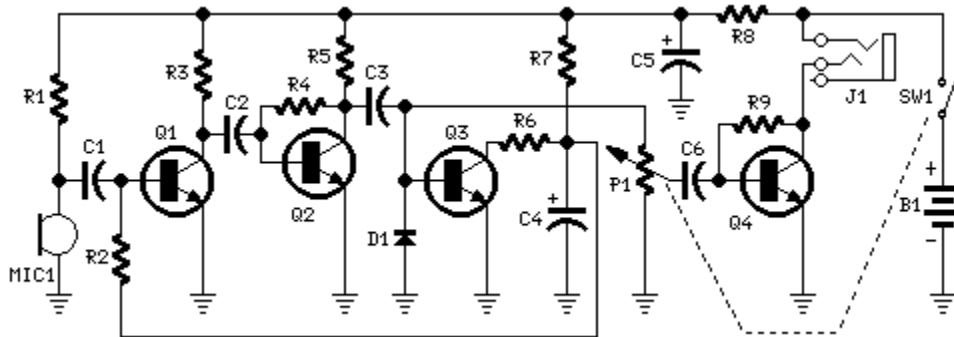

Parts:

P1 _____ 22K Log. Potentiometer (see Notes)

R1, R9 _____ 10K 1/4W Resistors

R2 _____ 1M 1/4W Resistor

R3 _____ 4K7 1/4W Resistor

R4, R7 _____ 100K 1/4W Resistor

R5 _____ 3K9 1/4W Resistor

R6 _____ 1K5 1/4W Resistor

R8 _____ 100R 1/4W Resistor

C1, C2 _____ 100nF 63V Polyester or Ceramic Capacitors

C3, C6 _____ 1 μ F 63V Polyester or Ceramic Capacitors

C4 _____ 10 μ F 25V Electrolytic Capacitor

C5 _____ 470 μ F 25V Electrolytic Capacitor

D1 _____ 1N4148 75V 150mA Diode

Q1, Q2, Q3, _____ BC547 45V 100mA NPN Transistors

Q4 _____ BC337 45V 800mA NPN Transistor

MIC1 _____ Miniature electret microphone

SW1 _____ SPST Switch (Ganged with P1)

J1 _____ Stereo 3mm. Jack socket

B1 _____ 1.5V Battery (AA or AAA cell etc.)

Device purpose:

This circuit, connected with 32 Ohms impedance mini-earphones, can detect very remote sounds. Useful for theatre, cinema and lecture goers: every word will be clearly heard. You can also listen to your television set at a very low volume, avoiding to bother relatives and neighbours. Even if you have a faultless hearing, you may discover unexpected sounds using this device: a remote bird twittering will seem very close to you.

Circuit operation:

The heart of the circuit is a constant-volume control amplifier. All the signals picked-up by the microphone are amplified at a constant level of about 1 Volt peak to peak. In this manner very low amplitude audio signals are highly amplified and high amplitude ones are limited. This operation is accomplished by Q3, modifying the bias of Q1 (hence its AC gain) by means of R2.

A noteworthy feature of this circuit is 1.5V battery operation.

Typical current drawing: 7.5mA.

Notes:

- | Due to the constant-volume control, some users may consider P1 volume control unnecessary. In most cases it can be omitted, connecting C6 to C3. In this case use a SPST slider or toggle switch as SW1.
- | Note the stereo output Jack socket (J1) connections: only the two inner connections are used, leaving open the external one. In this manner the two earpieces are wired in series, allowing mono operation and optimum load impedance to Q4 (64 Ohms).
- | Using suitable miniature components, this circuit can be enclosed in a very small box, provided by a clip and hanged on one's clothes or slipped in a pocket.